

Pressure Vacuum Vent with Flame Arrester



II G IIA



Mod. 197 EN-P

EN 16852:2010



APPLICATION

The pressure vacuum vent is normally used in the vapour recovery system (**Stage 1**).

It is designed to regulate the pressure inside the underground storage tank and to protect it in case of overpressure. It even helps to reduce the evaporation of fuel and environmental pollution.

Flame arrester element is designed to isolate flames and protect the tank from transmission of flames.



CHARACTERISTICS

Housing	Anodized aluminium	
Thread	BSP ISO 228-1	
Flame proof element/material	Ribbon coil / Stainless steel AISI 304	
Spring	Steel	
Poppet	Brass / stainless steel	
Standard vacuum	- 2,5 mbar	
Standard pressure	+ 35 mbar	
Arrester element width/diameter	10 mm / 90 mm	
Arrester element standard gap (MESG)	0,9 mm	
Burning class	C	
Distance from ignition source:	50 Lu/D	
EC design test certificate No.	CEC 12 ATEX 072 - Rev.2	12/2029-AET 997



DRAWING

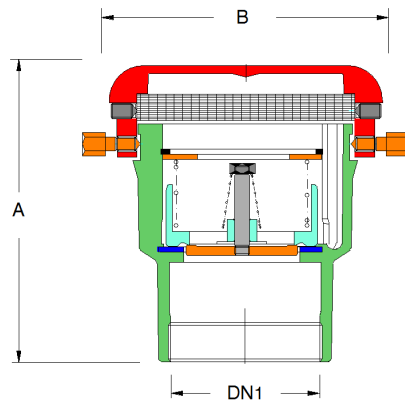

DIMENSIONS

Article No.	Pressure	DN 1	A	B	C
197 EN P-10	10 mbar	2" BSP Female	120 mm	115 mm	70
197 EN P-35*	35 mbar	2" BSP Female	120 mm	115 mm	70
197 EN P-50	50 mbar	2" BSP Female	120 mm	115 mm	70
197 EN P-80	80 mbar	2" BSP Female	120 mm	115 mm	70

* standard measure available in warehouse

INSTALLATION AND MAINTENANCE

The valve can be installed **on the pipework end line** of the vapour recovery system Stage 1.

For the installation of anti-deflagration pressure vacuum vent it is necessary to follow the Directives of flame arrester application, therefore strictly comply with the L/D ratio (pipe length/pipe diameter) and insure that the distance between potential ignition sources and the device does not exceed the max ratio of 50 L/D that corresponds to explosion group IIA and IIB3 (NEC groups D to C) according to EN ISO 16852. For other specific application and maintenance contact our technical department.

It is recommended to periodically inspect the valve for possible dirty, nests of insects. In the spring-loaded version it is necessary to periodically check the integrity of the spring.

The cap can be also removed to check up the good conditions of the flame arrester element.

Type-approved according to ATEX Directive 94/9/EC and EN ISO 16852.

RELATED PRODUCTS

