	Dichiarazione CE di Conformità Manuale di Uso e Manutenzione		DOC
	442S	rev.04 del 25-06-2022	Pag. 1/19

ISTRUZIONI DI INSTALLAZIONE, USO, MANUTENZIONE e SICUREZZA

VALVOLA LIMITATRICE DI CARICO RIDART 442S-80 AL & 442S-80 PTFE

FASCICOLO TECNICO: RIDART 01/22 ATEX

CARATTERISTICHE

Valvola limitatrice di carico, accessorio di sicurezza per serbatoi interrati contenenti carburati liquidi e prodotti chimici (scheda tecnica disponibile sul nostro sito web).

	<p>I nostri prodotti sono dispositivi di sicurezza ATEX per la protezione in caso di riempimento eccessivo del serbatoio con le seguenti limitazioni di utilizzo:</p> <ul style="list-style-type: none"> • Sono prodotti puramente meccanici. • Non hanno nessun componente elettronico ed elettrici. • Classificazione in categorie per Gas, vapori o nebbia (G). • Utilizzabile in qualsiasi zona anche in zona zero. • Temperatura di utilizzo tra -20°C e +40°C. <p>WARNING: Deve essere installata in posizione verticale in modo che il 90% del riempimento del serbatoio coincida con il livello massimo di chiusura della valvola che si trova a 110 mm dalla parte superiore della valvola.</p> <ul style="list-style-type: none"> • Il serbatoio deve essere dotato di secondario sensore di livello che possa dare un allarme al personale dedicato all'operazione di scarico. • Tutti i modelli non sono vapour tight. • La valvola può essere usata sia a pompa che a gravità, pressione massima di utilizzo è 8 bar per modelli da 3". • Valutare correttamente la tipologia di prodotto che sia compatibile con il liquido da utilizzare. <p>COMPATIBILITA' CHIMICA - ANNEX C norm 14879-4 Group 2 (carburanti tradizionali) 442S-80 AL prodotte con componenti in AL, PE e PTFE Carbon. Group 5, Group 7 & Group 8 (carburanti additivati, solventi e altro) <ul style="list-style-type: none"> • 442S-80 PTFE prodotte con componenti in AL ptf coated, PE and PTFE Carbon. </p> <p style="text-align: center;">TROPPIA TURBOLENZA IN FASE DI SCARICO POTREBBE ANTICIPARE IL LIVELLO DI CHIUSURA DELLA VALVOLA.</p>
--	--

4	25/6/22	Adeguamento alla nuova certificazione	Favarin D.	Meneghini D.
3	20/12/21	Modifiche richieste Organo Controllo	Favarin D.	Meneghini D.
2	8/07/16	Traduzione testi in Inglese, Francese e Tedesco	Favarin D.	Meneghini D.
1	18/05/16	Modifiche richieste Organo Controllo	Favarin D.	Meneghini D.
0	15/02/10	Prima emissione	Meneghini D.	Meneghini D.
Revisione	Data	Descrizione	Verificato	Approvato

POSIZIONAMENTO ed INSTALLAZIONE

Viene utilizzato su tubazioni ove richiesto, sotto il passo d'uomo, in posizione verticale in modo che la cisterna si riempia al massimo al 90% della sua capacità totale, fare riferimento alle specifiche omologazioni del Ministero degli Interni e agli schemi di impianto disponibili sul nostro sito web.

Indispensabile controllare prima dell'installazione il corretto movimento del galleggiante e la chiusura del piattello, che la verniciatura sia in perfetto stato e non presenti parti metalliche scoperte e che nessuna parte mobile o fissa della valvola o dell'impianto possa con l'uso creare un urto tra le parti e generare una scintilla all'interno del serbatoio.

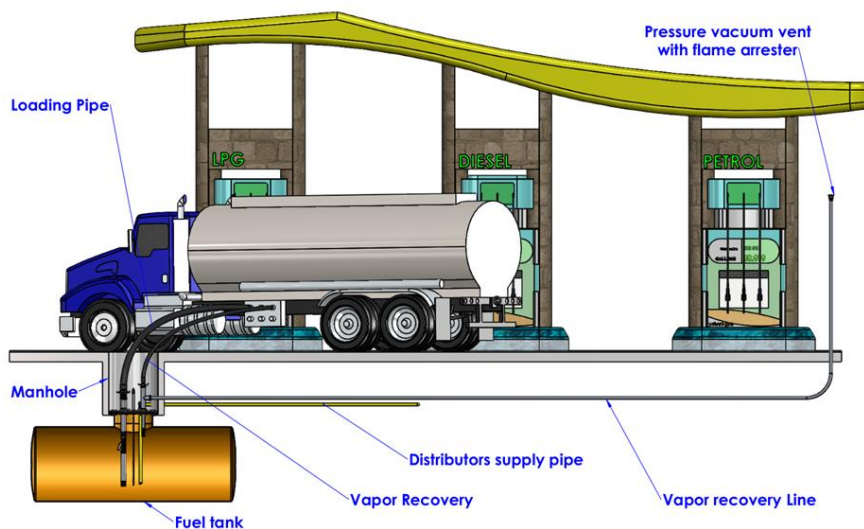

MANUTENZIONE

La frequenza dipende dall'utilizzo del prodotto e dalla presenza di corpi estranei nelle tubazioni. Consigliata la rimozione ove possibile e la pulizia almeno una volta ogni 12 mesi, intensificare la manutenzione in condizioni di uso gravoso, eliminare con accuratezza tutti i corpi esterni e depositi di ogni genere presenti all'interno e all'esterno del dispositivo di sicurezza, verificare il corretto funzionamento delle parti mobili e sostituire se necessario ove presenti guarnizioni e molle appena perdono di efficacia e/o di efficienza.

Per qualsiasi informazione contattare il costruttore:

RIDART S.R.L.

21045 Gazzada Schianno (VA) Italy

Tel. (+39) 0332 463301

Email: commerciale@ridart.it

Web: www.ridart.it e www.ridart.it/support



X - Pericolo di esplosione!

La mancata osservanza delle istruzioni contenute in questo capitolo può portare a severi danni alle persone e all'ambiente! Tali istruzioni non prescindono da un utilizzo appropriato dell'attrezzatura e dalle istruzioni riportate nel manuale di istruzioni generico.

	Dichiarazione CE di Conformità Manuale di Uso e Manutenzione		DOC
	442S	rev.04 del 25-06-2022	<i>Pag. 3/19</i>

GENERALITA'

Le attrezzature **RIDART S.R.L.** non presentano sorgenti di accensione in condizioni di funzionamento normale e di disfunzione prevista purché siano adottate le seguenti misure:

- Corretta installazione, controllando in corretto movimento del piattello, del galleggiante e il perfetto stato di conservazione e assemblaggio del prodotto.
- Utilizzo nel range di funzionamento definito sulla scheda tecnica del prodotto.
- Adozione delle presenti istruzioni aggiuntive.
- Utilizzo di ricambi autorizzati.
- Non apportare nessuna modifica ai sistemi.
- Perfetto stato della vernice.

CONDUTTIVITA' ELETTRICA

Tutta l'attrezzatura è costruita in modo da garantire la conducibilità. L'utilizzatore deve preoccuparsi di garantire la continuità con l'impianto e che esso sia messo a terra conformemente ai requisiti cogenti applicabili incluse le indicazioni della TR 50404. Oltre modo l'impianto deve essere protetto da scariche elettriche atmosferiche.

CLASSE di TEMPERATURA

La temperatura dell'attrezzatura dipende dalla temperatura del fluido convogliato, dalla temperatura del serbatoio e dell'ambiente esterno. La temperatura massima del liquido, del serbatoio e dell'ambiente non deve superare i 40°C e la minima non essere inferiore a -20°C. In caso in cui la temperatura ambiente è fuori dal range di utilizzo vanno presi dei provvedimenti per riportare serbatoio, liquido e attrezzatura tra i +40°C e -20°C. Vietato usare liquidi o miscele di liquidi che possono generare una reazione chimica esotermica.

PULIZIA e MANUTENZIONE

L'attrezzatura deve essere adeguatamente immagazzinata, movimentata e mantenuta onde prevenire l'ingresso di materiale ed il deposito di polvere tra le parti mobili. Le attività di manutenzione devono essere svolte esclusivamente da personale specializzato e secondo quanto definito nel manuale di istruzioni generico e con utensili conformi a quanto definito nell'Appendice A della norma UNI EN 1127-1 ed assicurandosi che non vi sia presenza di atmosfera esplosiva. In caso di malfunzionamento gli unici autorizzati a revisionare il dispositivo di protezione sono i tecnici di Ridart. Verificare sia in fase di installazione che in fase di manutenzione l'ottimo stato della vernice, non deve presentare nessun graffio o rottura che esponga il materiale ad un possibile contatto.



GARANZIA

- I prodotti sono garantiti per un anno (dalla data di fatturazione) contro tutti i difetti di fabbricazione da noi riconosciuti.
- Eventuali modifiche o manomissioni del prodotto avranno come conseguenza la perdita della garanzia e la possibile perdita di efficacia e efficienza del prodotto stesso.
- Se non verranno da noi installate, non potrà essere preteso alcun indennizzo supplementare al costo stesso della attrezzatura e per qualsiasi causa.
- Installazione e manutenzione deve essere eseguita solo da personale correttamente informato, formato e addestrato per garantire il corretto funzionamento del dispositivo di sicurezza.
- In caso di malfunzionamento il prodotto può essere revisionato solo da Ridart.
- Il funzionamento corretto del prodotto è tale solo se l'intero impianto è a norma e tutte le parti installate sono fisse e vincolate per evitare contatti tra il dispositivo di sicurezza e qualsiasi altra parte metallica che può generare una scintilla per impatto.



 Valves and fuel handling	Dichiarazione CE di Conformità Manuale di Uso e Manutenzione		DOC
	442S	rev.04 del 25-06-2022	Pag. 4/19

MARCATURA

 <p>OVERFILL VALVE 442S-80 AL 3" FINAL CLOSING LEVEL 110 mm by the top. CE 477 Ex II 1G Ex h IIB T6 Ga EN 13616:2016 XXXXXXXXXXXXXXXXXX Ridart S.r.l. - Via Adua 17 Gazzada Schianno (VA) Italy S.N. 41763 8/2020</p> <p>RIDART </p> <p>MADE IN ITALY VAPOUR TIGHT NO GRAVITY or PUMP MAX PRESSURE 8 bar Temperature: -20°C +40°C</p>	<p>La marcatura di ogni singolo dispositivo viene fatta sulla superficie della custodia tramite laser.</p> <p>Qui sotto la descrizione dell'etichettatura dei nostri dispositivi:</p> <ul style="list-style-type: none"> • "RIDART S.R.L." identifica la ragione sociale del produttore. • "VIA ADUA 17 GAZZADA SCHIANNO" è indirizzo di produzione del dispositivo. • "FIG. 442S-80-AL" identifica univocamente la tipologia di prodotto. • "S.N. XXXXX" è il serial number che identifica univocamente il singolo dispositivo. • "2022" identifica l'anno di produzione. • "XXXXXXXX" è il numero del certificato rilasciato dall'organismo notificato secondo allegato III della direttiva 2014/34/UE. • "RIDART 01/22 ATEX" è il numero del fascicolo tecnico Ridart secondo allegato III della direttiva 2014/34/UE. <p>La marcatura secondo la direttiva ATEX 2014/34/UE prevede invece:</p> <ul style="list-style-type: none"> • "CE" è simbolo della comunità europea; • "477" identifica l'organismo che effettua il controllo della produzione; • "Ex" è il simbolo specifico della direttiva ATEX 2014/34/UE; • "II" il prodotto è un dispositivo puramente meccanico. • "I" prodotto adatto ad atmosfere esplosive ZONA ZERO. • "G" prodotto adatto ad atmosfere esplosive causate da Gas, Vapori o Nebbie;
---	---

OGNI PRODOTTO VIENE CORREDATO DALLA SEGUENTE PLACCA CHE VIENE INSTALLATA NEL PASSO D'UOMO IN MODO DA IDENTIFICARE UNIVOCAMENTE LA TIPOLOGIA DI VALVOLA E DARE LE CORRETE ISTRUZIONI DI LAVORO AGLI ADDETTI ALLA FASE DI SCARICO.



LA PLACCA RIPORTA LE SEGUENTI INFORMAZIONI:

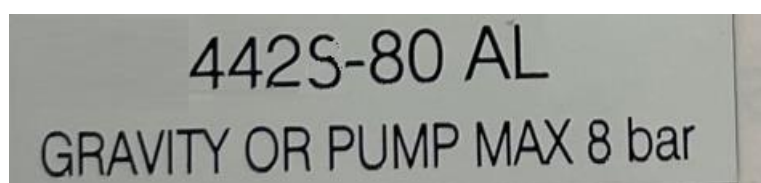

	Dichiarazione CE di Conformità Manuale di Uso e Manutenzione		DOC
	442S	rev.04 del 25-06-2022	<i>Pag. 5/19</i>

Sede operativa RIDART S.R.L.
Via Adua 17 – 21040 Gazzada Schianno (VA)
Tel. +39 0332 463301
Fax +39 0332 873065
commerciale@ridart.it

Sede legale RIDART S.R.L.
Via A. da Brescia, 2
21013 Gallarate (VA)
C.C.I.A.A. Varese 183072
C.F e P.IVA 01454770122

**DECLARATION OF CONFORMITY EU
DICHIARAZIONE DI CONFORMITA' UE**



Manufacturer's name
Nome del costruttore

RIDART S.R.L.

Manufacturer's address
Indirizzo del costruttore

Via Adua 17 - Gazzada Schianno (VA)

***Herewith declares under own exclusive responsibility conformity of the Products
Dichiara sotto la propria responsabilità esclusiva la conformità del prodotto***

Product description:
Descrizione del prodotto

**OVERFILL PREVENTION valve - Valvola limitatrice
442S-80 AL (s.n. 2022->2023)
442S-80 PTFE (s.n. 2022->2023)**

Marking
Marcatura



II 1G Ex h IIB T6 Ga

Certificate Number edit by Eurofins,
Notified Body Number 0477
Numero certificato emesso da Eurofins,
Organismo Notificato Numero 0477

EPT 23 ATEX 5043

Technical File Number
Numero Fascicolo Tecnico

RIDART 01/22 ATEX

In accordance with applicable regulations below:
Soddisfa la seguente Direttiva:

EU Directive / Direttiva UE: **2014/34/UE - ATEX**

As in accordance to the European Harmonized Standards applied when the certificate was issued:
In quanto conforme alle Norme Europee Armonizzate applicabili alla data di emissione del
certificato sopra indicato:

EN ISO 13616-1:2016; EN ISO 80079-36:2016

Gazzada Schianno li 25 GIUGNO 2022

firma
 Davide Meneghini (CEO)



	Dichiarazione CE di Conformità Manuale di Uso e Manutenzione		DOC
	442S	rev.04 del 25-06-2022	<i>Pag. 6/19</i>

Sede operativa RIDART S.R.L.
Via Adua 17 – 21040 Gazzada Schianno (VA)
Tel. +39 0332 463301
Fax +39 0332 873065
commerciale@ridart.it

Sede legale RIDART S.R.L.
Via A. da Brescia, 2
21013 Gallarate (VA)
C.C.I.A.A. Varese 183072
C.F e P.IVA 01454770122

**UK DECLARATION OF CONFORMITY
DICHIARAZIONE DI CONFORMITA' REGNO UNITO**



Manufacturer's name
Nome del costruttore **RIDART S.R.L.**

Manufacturer's address
Indirizzo del costruttore **Via Adua 17 - Gazzada Schianno (VA)**

***Herewith declares under own exclusive responsibility conformity of the Products
Dichiara sotto la propria responsabilità esclusiva la conformità del prodotto***

Product description:
Descrizione del prodotto **OVERFILL PREVENTION valve - Valvola limitatrice
442S-80 AL (s.n. 2022->2023)
442S-80 PTFE (s.n. 2022->2023)**

Marking
Marcatura  **II 1G Ex h IIB T6 Ga**

Certificate Number edit by Eurofins,
Notified Body Number 0477 **EPT 23 ATEX 5043**
Numero certificato emesso da Eurofins,
Organismo Notificato Numero 0477

Technical File Number
Numero Fascicolo Tecnico **RIDART 01/22 ATEX**

In accordance with applicable regulations below:
Soddisfa la seguente Direttiva:

EU Directive / Direttiva UE: **2014/34/UE - ATEX**

As in accordance to the European Harmonized Standards applied when the certificate was issued:
In quanto conforme alle Norme Europee Armonizzate applicabili alla data di emissione del
certificato sopra indicato:

EN ISO 13616-1:2016; EN ISO 80079-36:2016

Gazzada Schianno li 25 GIUGNO 2022

firma
 Davide Meneghini (CEO)



INSTALLATION, USE, MAINTENANCE and SAFETY INSTRUCTIONS OVERFILL PREVENT VALVES

RIDART 442S-80 AL & 442S-80 PTFE

TECHNICAL FILE: RIDART 01/22 ATEX

FEATURES

Mechanical safety device to be installed on charge line in fuel plants or chemical products (technical data sheet available on our website).



TOO MUCH TURBULENCE
DURING UNLOADING COULD
ADVANCE THE VALVE CLOSING
LEVEL.

Our products are ATEX safety devices for protection in case of overfilling of the tank with the following limitations of use:

- They are purely mechanical products.
- They have no electronic and electrical components.
- Classification into categories for Gas, vapor or mist (G).
- Can be used in any zone even in the zero zone.
- Temperature of use between -20 ° C and + 40 ° C.

WARNING:

It must be installed in a vertical position so that 90% of the filling of the tank coincides with the maximum closing level of the valve which is 110 mm from the top of the valve.

- The tank must be equipped with a secondary level sensor that can give an alarm to the personnel dedicated to the unloading operation.
- All models are not vapor tight.
- The valve can be used both by pump and by gravity, the maximum pressure of use is 8 bar.
- Correctly evaluate the type of product that is compatible with the liquid to be used.

CHEMICAL PRODUCT - ANNEX C norm 14879-4

Group 2

- For valve with AL, PE and PTFE Carbon component.

Group 5, Group 7 & Group 8

- For valve with AL ptfе coated, PE and PTFE Carbon component.

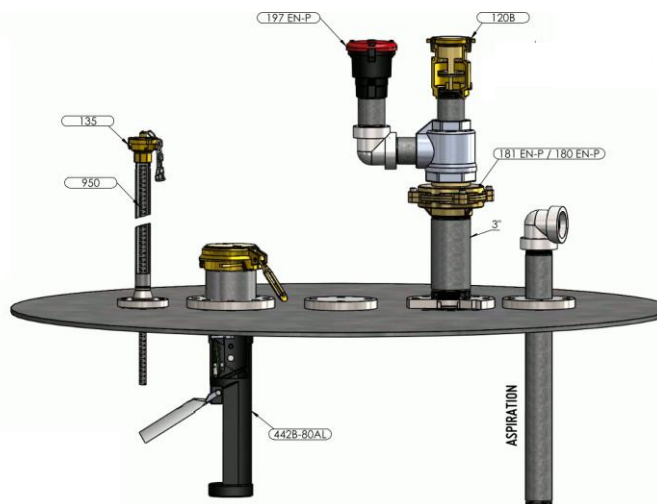

INSTALLATION and POSITIONING

Used on pipes where required, under the manhole, in a vertical position so that the tank is filled to a maximum 90% of its total capacity, refer to the specific approval of the Italian “Ministry of Internal” and the schemes on facility available at our website, the floater must be under the seal.

Before installation, it is necessary to check the correct movement of the float and the closure of the plate, that the painting is in perfect condition and that there are no exposed metal parts and that no mobile or fixed part of the valve or system can create a Collision between parts and generates a spark inside the tank.

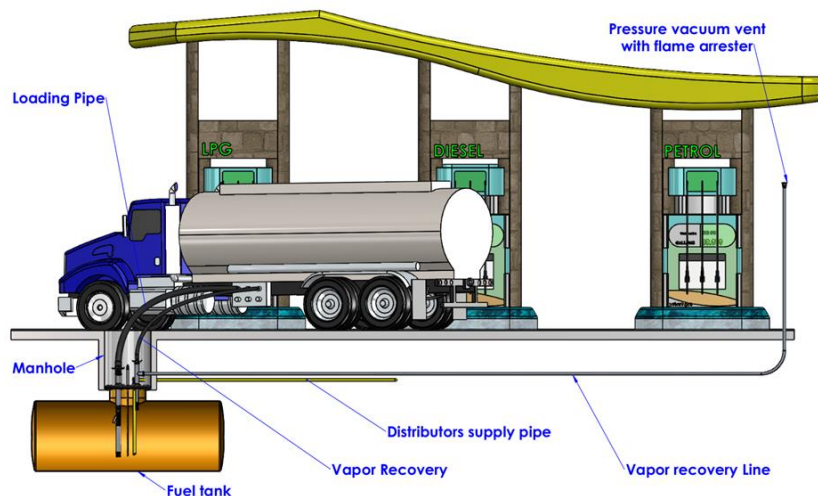

MAINTENANCE

Frequency depends on product's using and foreign bodies in the pipe. If it's possible removing and cleaning at least once every 12 months, intensify the maintenance in heavy using, carefully remove all external bodies and deposits, inside and outside of the safety device, check the proper functioning of moving parts and replace if necessary, any seals and springs when their effectiveness and efficiency decrease.

For any questions call the manufacturer:

RIDART S.R.L.

21045 Gazzada Schianno (VA) Italy

Tel. (+39) 0332 463301

Email: commerciale@ridart.it

Web: www.ridart.it e www.ridart.it/support



X Danger Explosion!

Failure to follow the instructions contained in this section may lead to severe damage to people and environment! These instructions do not disregard the proper use of the equipment and the instruction manual of generic instructions.

	Dichiarazione CE di Conformità Manuale di Uso e Manutenzione		DOC
	442S	rev.04 del 25-06-2022	<i>Pag. 9/19</i>

GENERAL

All RIDART's equipment are not sources of ignition in normal operation or in malfunction conditions, you have to respect these following instructions:

- Correct installation, checking the correct movement of the plate, the float and the perfect state of conservation and assembly of the product.
- Use only into the operating range defined in the Product Data Sheet
- Use all additional instructions.
- Use only RIDART and authorized spare parts.
- Make no changes to the systems.
- Perfect condition of the paint.

ELECTRICAL CONTINUITY

All RIDART's equipment are made to ensure the electrical conductivity.

The user and the installer must take care to ensure continuity with the system and the grounding in accordance with legal requirements including in TR 50404. In addition, the system must be protected from atmospheric electric discharges.



TEMPERATURE CLASS

The temperature of the equipment depends on the temperature of the fluid conveyed, the temperature of the tank and the external environment. The maximum temperature of the liquid, the tank and the environment must not exceed 40°C and the minimum not be lower than -20°C. If the ambient temperature is out of the usage range, measures must be taken to bring the tank, liquid and equipment back to between +40°C and -20°C. It is forbidden to use liquids or mixtures of liquids that can generate an exothermic chemical reaction.

CLEANING and MAINTENANCE



The equipment must be adequately stored, handled and maintained to prevent the entry of material and the deposition of dust between moving parts. Maintenance activities must be carried out exclusively by specialized personnel and according to what is defined in the generic instruction manual and with tools compliant with what is defined in Appendix A of the UNI EN 1127-1 standard and making sure that there is no explosive atmosphere. In the event of a malfunction, the only ones authorized to overhaul the protection device are Ridart technicians. Check the excellent condition of the paint both during installation and maintenance, it must not show any scratches or breaks that expose the material to possible contact.

WARRANTY

- Products are warranted for one year (from invoice's data) against all manufacturing defects that we recognized.
- Any product 's modifications or tampering will lose your warranty and equipment's effectiveness and efficiency, please don't do it.
- Any extra compensation cannot be demand, if we don't install equipment or for any other reason.
- Installation and maintenance must only be carried out by personnel who are properly informed, trained and trained to guarantee the correct functioning of the safety device.
- The correct functioning of the product is such only if the entire system complies with the law and all the installed parts are fixed and constrained to avoid contact between the safety device and any other metal part which can generate a spark by impact.

 Valves and fuel handling	Dichiarazione CE di Conformità Manuale di Uso e Manutenzione		DOC
	442S	rev.04 del 25-06-2022	<i>Pag. 10/19</i>

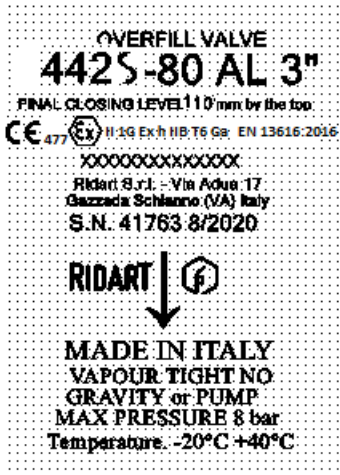
MARKING

 <p>OVERFILL VALVE 442S-80 AL 3" FINAL CLOSING LEVEL 110 mm by the top. CE 477 Ex II 1G Ex h IIB T6 Ga EN 13616:2016 XXXXXXXXXXXXXXXX Ridart S.r.l. - Via Adua 17 Gazzada Schianno (VA) Italy S.N. 41763 8/2020</p> <p style="text-align: center;">  MADE IN ITALY VAPOUR TIGHT NO GRAVITY or PUMP MAX PRESSURE 8 bar Temperature: -20°C +40°C </p>	<p>The marking of each individual device is done on the surface of the case by laser. Below is the description of the labeling of our devices:</p> <ul style="list-style-type: none"> • "RIDART S.R.L." identifies the company name of the manufacturer. • "VIA ADUA 17 GAZZADA SCHIANNO" is the device's production address. • "FIG. 442S-80-AL "uniquely identifies the type of product. • "S.N. XXXXX "is the serial number that uniquely identifies the single device. • "2022" identifies the year of production. • "XXXXXXXX" is the number of the certificate issued by the notified body according to Annex III of Directive 2014/34 / EU. • <input type="checkbox"/> "RIDART 01/22 ATEX" is the number of the Ridart technical file according to Annex III of Directive 2014/34 / EU. <p>The marking according to the ATEX directive 2014/34 / EU instead provides:</p> <ul style="list-style-type: none"> • "CE" is the symbol of the European community; • "477" identifies the body that carries out the production control; • "Ex" is the specific symbol of the ATEX directive 2014/34 / EU; • "II" the product is a purely mechanical device. • "1" product suitable for ZERO ZONE explosive atmospheres. • "G" product suitable for explosive atmospheres caused by Gas, Vapors or Mists;
---	--

EACH PRODUCT IS EQUIPPED WITH THE FOLLOWING PLATE THAT IS INSTALLED IN THE MANHOLE IN ORDER TO UNIVOCALLY IDENTIFY THE VALVE TYPES A AND GIVE THE CORRECT WORKING INSTRUCTIONS TO THE EMPLOYEES DURING THE UNLOADING PHASE.



THE PLATE SHOWS THE FOLLOWING INFORMATION:

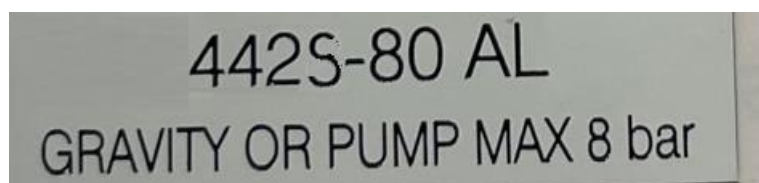

**INSTRUCTIONS D'INSTALLATION, UTILISATION, ENTRETIEN et SECURITE
LIMITEUR DE REMPLISSAGE****RIDART 442S-80 AL &
442S-80 PTFE****FICHE TECHNIQUE : RIDART 01/22 ATEX****CARACTÉRISTIQUES**

Limiteur de remplissage (fiche technique/schéma disponible sur notre site).



TROP DE TURBULENCE
PENDANT LE DÉCHARGEMENT
POURRAIT AVANCER LE
NIVEAU DE FERMETURE DE LA
VANNE.

Nos produits sont des dispositifs de sécurité ATEX pour la protection en cas de trop-plein du réservoir avec les limitations d'utilisation suivantes :

- Ce sont des produits purement mécaniques.
- Ils n'ont pas de composants électroniques et électriques.
- Classement en catégories pour Gaz, vapeur ou brouillard (G).
- Peut être utilisé dans n'importe quelle zone même dans la zone zéro.
- Température d'utilisation entre -20°C et + 40°C.

ATTENTION:

Il doit être installé en position verticale de manière à ce que 90% du remplissage du réservoir coïncide avec le niveau maximum de fermeture de la vanne qui est à 110 mm du haut de la vanne.

- Le réservoir doit être équipé d'un capteur de niveau secondaire pouvant donner une alarme au personnel dédié à l'opération de déchargement.

- Tous les modèles ne sont pas étanches à la vapeur.

- La vanne peut être utilisée aussi bien par pompe que par gravité, la pression maximum d'utilisation est de 8 bar pour les modèles 3".

- Évaluer correctement le type de produit compatible avec le liquide à utiliser.

PRODUIT CHIMIQUE - ANNEXE C norme 14879-4

Groupe 2

- Pour vanne avec composant carbone AL, PE et PTFE.

Groupe 5, Groupe 7 et Groupe 8

- Pour vanne avec revêtement AL ptfé, composant PE et PTFE Carbone.

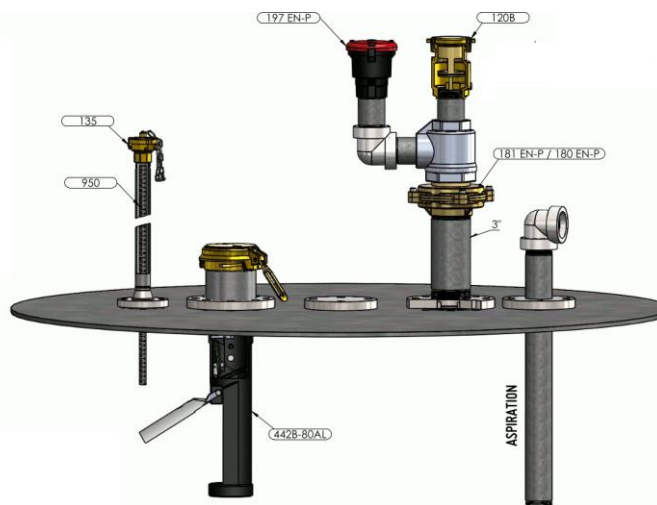

INSTALLATION

Montage direct sur tube, sous le trou d'homme dans une position verticale, de sorte que le réservoir est rempli jusqu'à un maximum de 90% de sa capacité totale. Reportez-vous à l'approbation spécifique du ministère de l'Intérieur (Italienne) et les schémas de système disponibles sur notre site Web, le cas échéant, vérifier que le flotteur est en dessous du joint.

Avant l'installation, il est nécessaire de vérifier le bon mouvement du flotteur et la fermeture de la plaque, que la peinture soit en parfait état et qu'il n'y ait pas de parties métalliques apparentes et qu'aucune partie mobile ou fixe de la vanne ou du système ne puisse créer a Collision entre les pièces et génère une étincelle à l'intérieur du réservoir.

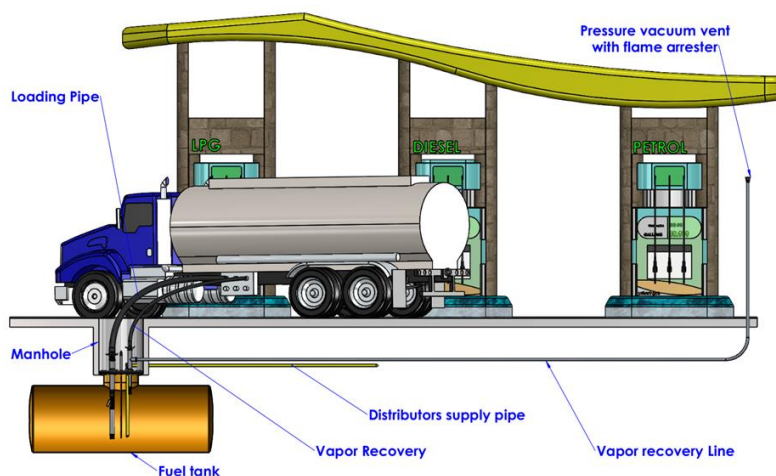

MAINTENANCE

Entretien dépend de l'utilisation du produit et à la présence de corrosion dans la tuyauterie, chaque année, une inspection/nettoyage sera réalisée par de personnel habilité La première intervention devra avoir lieu au plus tard 12 mois après la mise en service , intensifier l'entretien dans des conditions d'utilisation intensive, éliminer avec précision tout genre des corps qu'ils ce dépôt à l'intérieur et à l'extérieur du dispositif de sécurité. vérifier le bon fonctionnement des pièces mobiles et remplacer si nécessaire tout joints et ressort de limeteur de remplissage permettant le bon fonctionnement.

Pour toute information s'il vous plaît contacter le fabricant:

RIDART S.R.L.

21045 Gazzada Schianno (VA) Italy

Tel. (+39) 0332 463301

Email: commerciale@ridart.it

Web: www.ridart.it e www.ridart.it/support



X - Risque d'explosion

Le non-respect des instructions contenues dans la présente section peut conduire à de graves dommages aux personnes et l'environnement! Ces instructions ne tiennent pas compte de l'utilisation appropriée de l'équipement et le manuel d'instruction génériques.

	Dichiarazione CE di Conformità Manuale di Uso e Manutenzione		DOC
	442S	rev.04 del 25-06-2022	<i>Pag. 13/19</i>

GENERALITES'

Tous les équipements RIDART ne sont pas des sources d'ignition en fonctionnement normal ou dans des conditions de dysfonctionnement, vous devez respecter ces instructions suivantes:

- Installation correcte.
- Il ne faut pas dépasser le fonctionnement définie dans la fiche technique du produit.
- Utilisez toutes les instructions supplémentaires.
- Utilisez uniquement les pièces de rechange autorisées.
- Ne modifiez pas les systèmes.

CONDUCTIVITE ELECTRIC

Tous les équipements RIDART sont fabriqué pour assurer la conductivité électrique. L'utilisateur et l'installateur doit prendre soin d'assurer la continuité avec le système et mise à la terre conformément aux exigences légales, y compris dans TR 50404.



CLASSE de TEMPÉRATURE

La température de l'équipement dépend de la température du réservoir et de la température du fluide véhiculé. La température maximale doit être inférieure à 40°C et supérieure à -20°C.

NETTOYAGE et MAINTENANCE

L'équipement doit être correctement stocké, manipuler et maintenu afin d'éviter la filtration de matière et le dépôt de poussière entre les parties mobiles. Les activités de maintenance doivent être effectués par de personnel spécialisé ayant une connaissance des risques et des moyens à mettre en oeuvre pour les prévenir, selon la définition rapporté dans le manuel d'instructions générales avec des outils conforme comme dans l'annexe A de la norme **UNI EN 1127-1** s'assurer qu'il n'y pas présence des risques associés à l'atmosphères: intoxication, inflammation, explosion.

GARANTIE

- Les produits sont garantis pendant 12 mois à partir de la date de facturation (sauf conditions particulières).
- Toute modification ou réparation réalisée sur les produits donnera lieu à la perte de la garantie et il peut provoquer le dysfonctionnement de produit.
- Toute les installations doivent être réalisée par le constructeur , dans les cas contraire Il ne peut pas être réclamé des indemnités supplémentaires pour aucun raison.
- L'installation et l'entretien doivent être effectués uniquement par du personnel dûment informé, formé et formé pour garantir le bon fonctionnement du dispositif de sécurité.

 Valves and fuel handling	Dichiarazione CE di Conformità Manuale di Uso e Manutenzione		DOC
	442S	rev.04 del 25-06-2022	Pag. 14/19

MARKING

 <p>OVERFILL VALVE 442S-80 AL 3" FINAL CLOSING LEVEL 110 mm by the top. CE 477 Ex II 1G Ex h IIB T6 Ga EN 13616:2016 XXXXXXXXXXXXXXXXXX Ridart S.r.l. - Via Adua 17 Gazzada Schianno (VA) Italy S.N. 41763 8/2020</p> <p>RIDART ↓</p> <p>MADE IN ITALY VAPOUR TIGHT NO GRAVITY or PUMP MAX PRESSURE 8 bar Temperature: -20°C +40°C</p>	<p>Le marquage de chaque appareil individuel se fait sur la surface du boîtier par laser. Ci-dessous la description de l'étiquetage de nos appareils :</p> <ul style="list-style-type: none"> • "RIDART S.R.L." identifie la raison sociale du fabricant. • « VIA ADUA 17 GAZZADA SCHIANNO » est l'adresse de production de l'appareil. • "FIGUE. 442S-80-AL "identifie de manière unique le type de produit. • "S.N. XXXXX "est le numéro de série qui identifie de manière unique l'appareil unique. • "2022" identifie l'année de production. • "XXXXXXXX" est le numéro du certificat délivré par l'organisme notifié conformément à l'annexe III de la directive 2014/34/UE. • « RIDART 01/22 ATEX » est le numéro du dossier technique Ridart selon l'annexe III de la directive 2014/34/UE. <p>Le marquage selon la directive ATEX 2014/34/UE prévoit à la place :</p> <ul style="list-style-type: none"> • « CE » est le symbole de la communauté européenne ; • « 477 » identifie l'organisme qui effectue le contrôle de production ; • « Ex » est le symbole spécifique de la directive ATEX 2014/34/EU ; • "II" le produit est un appareil purement mécanique. • Produit « 1 » adapté aux atmosphères explosives ZERO ZONE. • Produit « G » adapté aux atmosphères explosives causées par des gaz, des vapeurs ou des brouillards ;
---	--

CHAQUE PRODUIT EST ÉQUIPÉ DE LA PLAQUE SUIVANTE QUI EST INSTALLÉE DANS LE REGARD AFIN D'IDENTIFIER DE FAÇON UNIVOQUE LES VANNES DE TYPE A ET DE DONNER LES INSTRUCTIONS DE TRAVAIL CORRECTES AUX EMPLOYÉS PENDANT LA PHASE DE DÉCHARGEMENT.



LA PLAQUE INDIQUE LES INFORMATIONS SUIVANTES :

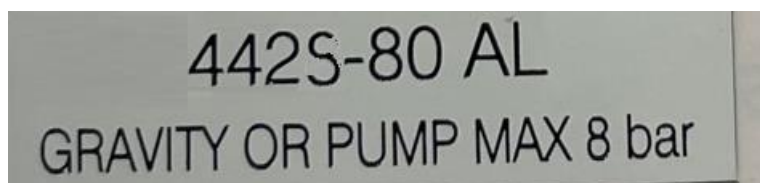

**INSTALLATION, NUTZUNG, WARTUNG und Sicherheitshinweise
LOAD VENTIL****RIDART 442S-80 AL &
442S-80 PTFE
TECHNISCHE KARTE: RIDART 01/22 ATEX****EIGENSCHAFTEN**

Mechanische Sicherheitsvorrichtung installiert werden auf Entlüftungen Brennstoffanlagen oder chemischen Erzeugnissen (technisches Datenblatt auf unserer Website).



**ZU VIEL TURBULENZEN
WÄHREND DES ENTLADENS
KÖNNTEN DEN
VENTILSCHLISSSTAND
VORSCHIEBEN.**

Unsere Produkte sind ATEX-Sicherheitseinrichtungen zum Schutz bei Überfüllung des Tanks mit folgenden Einsatzbeschränkungen:

- Es handelt sich um rein mechanische Produkte.
- Sie haben keine elektronischen und elektrischen Komponenten.
- Einstufung in Kategorien für Gas, Dampf oder Nebel (G).
- Kann in jeder Zone verwendet werden, sogar in der Nullzone.
- Gebrauchstemperatur zwischen -20 °C und +40 °C.

WARNUNG:

Es muss in vertikaler Position installiert werden, damit 90 % der Füllung des Tanks mit dem maximalen Schließniveau des Ventils, das 110 mm von der Oberkante des Ventils entfernt ist, zusammenfallen.

- Der Tank muss mit einem sekundären Niveausensor ausgestattet sein, der dem mit dem Entladevorgang beauftragten Personal einen Alarm geben kann.
- Alle Modelle sind nicht dampfdicht.
- Das Ventil kann sowohl per Pumpe als auch per Schwerkraft verwendet werden, der maximale Betriebsdruck beträgt 8 bar für 3-Zoll-Modelle.
- Bewerten Sie den Produkttyp, der mit der zu verwendenden Flüssigkeit kompatibel ist.

CHEMISCHES ERZEUGNIS - ANHANG C Norm 14879-4**Gruppe 2**

- Für Ventil mit AL, PE und PTFE Kohlekomponente.

Gruppe 5, Gruppe 7 und Gruppe 8

- Für Ventile mit AL-PTFE-beschichteter, PE- und PTFE-Kohlenstoffkomponente.

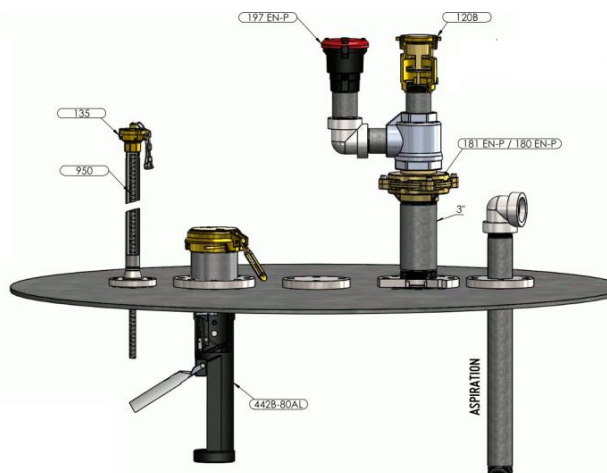

INSTALLATION und AUFSTELLUNG

Auf Rohren, wo erforderlich, unter den Schacht, in einer vertikalen Position, so dass der Tank bis zu einem Maximum 90% seiner Gesamtkapazität gefüllt ist, beziehen sich auf die ausdrückliche Zustimmung des italienischen "Innen Ministerium" und die Regelungen über die Anlage zur Verfügung zu unserer Website muss der Schwimmer unter dem Siegel sein.

Vor der Installation ist es notwendig, die korrekte Bewegung des Schwimmers und des Verschlusses der Platte zu überprüfen, dass die Lackierung in einwandfreiem Zustand ist und dass keine freiliegenden Metallteile vorhanden sind und dass kein beweglicher oder fester Teil des Ventils oder Systems entstehen kann a Kollision zwischen Teilen und erzeugt einen Funken im Inneren des Tanks.

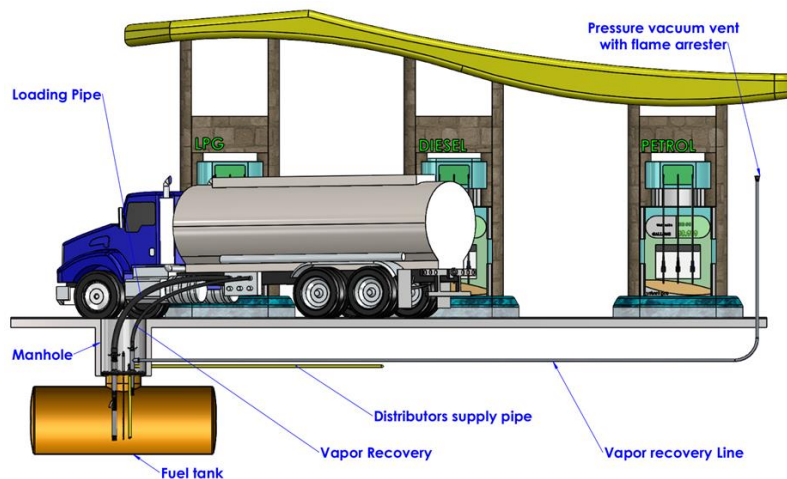

INSTANDHALTUNG

Frequency depends on product's using and foreign bodies in the pipe. If it's possible removing and cleaning at least once every 12 months, intensify the maintenance in heavy using, carefully remove all external bodies and deposits, inside and outside of the safety device, check the proper functioning of moving parts and replace if necessary any seals and springs when their effectiveness and efficiency decrease.

Bei Fragen rufen Sie den Hersteller:

RIDART S.R.L.

21045 Gazzada Schianno (VA) Italy

Tel. (+39) 0332 463301

Email: commerciale@ridart.it

Web: www.ridart.it e www.ridart.it/support



X - Gefahr Explosion!

Wenn die Anweisungen in diesem Abschnitt enthaltenen folgen kann zu schweren Schäden für Menschen und Umwelt führen! Diese Anweisungen ignorieren nicht die ordnungsgemäße Verwendung der Ausrüstung und der Bedienungsanleitung allgemeine Anweisungen.

	Dichiarazione CE di Conformità Manuale di Uso e Manutenzione		DOC
	442S	rev.04 del 25-06-2022	<i>Pag. 17/19</i>

GENERAL

Alle RIDART der Geräte keine Zündquellen im Normalbetrieb oder bei Störung Bedingungen sind, müssen Sie diese folgenden Hinweise zu beachten:

- Überprüfung der korrekten Bewegung der Platte, des Schwimmers und des einwandfreien Erhaltungs- und Montagezustands des Produkts.
- Verwenden Sie nur in den Arbeitsbereich im Produktdatenblatt definiert
- Verwenden Sie alle weiteren Anweisungen.
- Verwenden Sie nur RIDART und autorisierte Ersatzteile.
- Nehmen Sie keine Änderungen an den Systemen.

ELEKTROGANG

Alle RIDART-Geräte sind darauf ausgelegt, elektrische Leitfähigkeit zu gewährleisten. Der Benutzer und der Installateur müssen dafür sorgen, dass die Kontinuität mit dem System und die Erdung gemäß den gesetzlichen Anforderungen, insbesondere in TR 50404, gewährleistet sind. Außerdem muss das System vor atmosphärischen elektrischen Entladungen geschützt werden.



TEMPERATURKLASSE

Die Temperatur der Ausrüstung hängt von der Temperatur des geförderten Mediums, der Temperatur des Tanks und der äußeren Umgebung ab. Die Höchsttemperatur der Flüssigkeit, des Tanks und der Umgebung darf 40 °C nicht überschreiten und die Mindesttemperatur nicht unter -20 °C liegen. Wenn die Umgebungstemperatur außerhalb des Verwendungsbereichs liegt, müssen Maßnahmen ergriffen werden, um den Tank, die Flüssigkeit und die Ausrüstung wieder auf eine Temperatur zwischen +40 °C und -20 °C zu bringen. Es ist verboten, Flüssigkeiten oder Flüssigkeitsgemische zu verwenden, die eine exotherme chemische Reaktion hervorrufen können.

Reinigung und Instandhaltung

Die Ausrüstung muss angemessen gelagert, gehandhabt und gewartet werden, um das Eindringen von Material und die Ablagerung von Staub zwischen beweglichen Teilen zu verhindern. Die Wartungstätigkeiten dürfen ausschließlich von Fachpersonal und gemäß den Definitionen in der allgemeinen Bedienungsanleitung und mit Werkzeugen durchgeführt werden, die den Definitionen in Anhang A der Norm UNI EN 1127-1 entsprechen und sicherstellen, dass keine explosionsfähige Atmosphäre vorhanden ist. Im Falle einer Fehlfunktion sind die einzigen Personen, die zur Überholung der Schutzvorrichtung berechtigt sind, Ridart-Techniker. Überprüfen Sie den hervorragenden Zustand des Lacks sowohl während der Installation als auch bei der Wartung. Er darf keine Kratzer oder Brüche aufweisen, die das Material einem möglichen Kontakt aussetzen.

GARANTIE

- Die Produkte werden für ein Jahr (von Rechnungen Daten) gegen alle Fabrikationsfehler garantiert, dass wir anerkannt.
- Jedes Produkt, 's Änderungen und Manipulationen wird die Garantie und Ausrüstung Effektivität und Effizienz verlieren, fügen Sie es nicht tun.
- Jede zusätzliche Kompensation kann nicht gefragt sein, wenn wir aus einem anderen Grund nicht Ausrüstung installieren oder.
- Installation und Wartung dürfen nur von entsprechend informiertem, geschultem und geschultem Personal durchgeführt werden, um die korrekte Funktion der Sicherheitseinrichtung zu gewährleisten.

 Valves and fuel handling	Dichiarazione CE di Conformità Manuale di Uso e Manutenzione		DOC
	442S	rev.04 del 25-06-2022	Pag. 18/19

MARKING

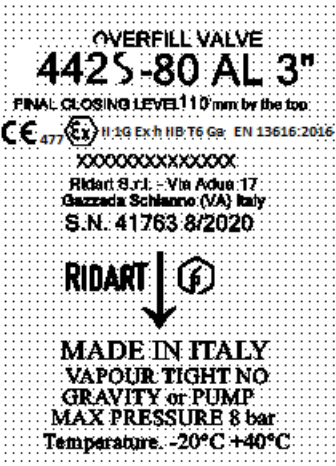
 <p>OVERFILL VALVE 442S-80 AL 3" FINAL CLOSING LEVEL 110 mm by the top. CE 477 Ex II 1G Ex h IIB T6 Ga EN 13616:2016 XXXXXXXXXXXXXXXXXX Ridart S.r.l. - Via Adua 17 Gazzada Schianno (VA) Italy S.N. 41763 8/2020</p> <p>RIDART ↓</p> <p>MADE IN ITALY VAPOUR TIGHT NO GRAVITY or PUMP MAX PRESSURE 8 bar Temperature: -20°C +40°C</p>	<p>Die Kennzeichnung jedes einzelnen Gerätes erfolgt auf der Gehäuseoberfläche per Laser.</p> <p>Nachfolgend finden Sie die Beschreibung der Kennzeichnung unserer Geräte:</p> <ul style="list-style-type: none"> • "RIDART S.R.L." kennzeichnet den Firmennamen des Herstellers. • „VIA ADUA 17 GAZZADA SCHIANNO“ ist die Produktionsadresse des Geräts. • "FEIGE. 442S-80-AL „identifiziert eindeutig den Produkttyp. • „S.N. XXXXX“ ist die Seriennummer, die das einzelne Gerät eindeutig identifiziert. • „2022“ kennzeichnet das Produktionsjahr. • „XXXXXXX“ ist die Nummer des von der notifizierten Stelle gemäß Anhang III der Richtlinie 2014/34/EU ausgestellten Zertifikats. • „RIDART 01/22 ATEX“ ist die Nummer der technischen Unterlagen von Ridart gemäß Anhang III der Richtlinie 2014/34 / EU. <p>Die Kennzeichnung nach der ATEX-Richtlinie 2014/34/EU sieht stattdessen vor:</p> <ul style="list-style-type: none"> • „CE“ ist das Symbol der Europäischen Gemeinschaft; • „477“ identifiziert die Stelle, die die Produktionskontrolle durchführt; • „Ex“ ist das spezifische Symbol der ATEX-Richtlinie 2014/34/EU; • „II“ das Produkt ein rein mechanisches Gerät ist. • „1“-Produkt geeignet für explosionsgefährdete Atmosphären im NULLBEREICH. • „G“-Produkt, geeignet für explosionsgefährdete Atmosphären, die durch Gase, Dämpfe oder Nebel verursacht werden;
---	---

JEDES PRODUKT IST MIT DEM FOLGENDEN PLATTE AUSGESTATTET, DAS IN DEN SCHACHT EINGEBAUT WIRD, UM DIE ARMATUR TYP A EINZIGARTIG ZU IDENTIFIZIEREN UND DEN MITARBEITERN WÄHREND DER ENTLADUNGSPHASE DIE RICHTIGEN ARBEITSANWEISUNGEN ZU GEBEN.



AUF DEM SCHILD WERDEN FOLGENDE INFORMATIONEN ANGEGBEN:

RIDART Valves and fuel handling	Dichiarazione CE di Conformità Manuale di Uso e Manutenzione		DOC
	442S	rev.04 del 25-06-2022	<i>Pag. 19/19</i>

442S-80 AL
GRAVITY OR PUMP MAX 8 bar