

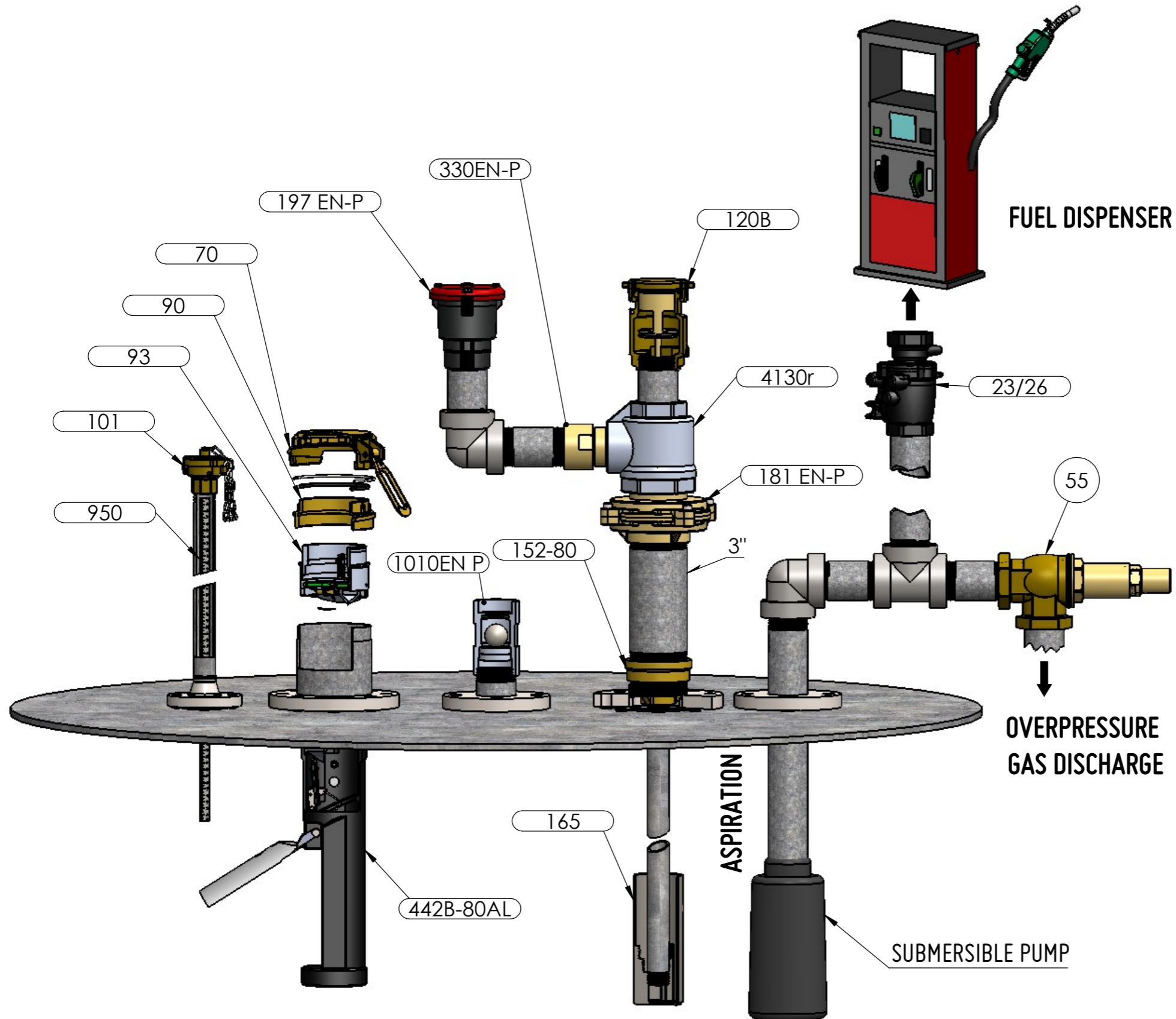

TYPICAL MANHOLE (GASOLINE-DIESEL-SPECIAL FUEL-CHEMICAL)



COD.	DESCRIPTION	GASOLINE	DIESEL	SPECIAL FUELS	CHEMICAL
23/26	SHUT OFF	V	V	PTFE COATED	STAINLESS STEEL
55	BY-PASS VALVE	V	V	PTFE COATED	STAINLESS STEEL
70	CAP	V	V	PTFE COATED	STAINLESS STEEL
90	QUICK ADAPTOR	V	V	PTFE COATED	STAINLESS STEEL
93	VAPOR STOP DEVICE	V	NR	PTFE COATED	STAINLESS STEEL
101	QUICK CAP FOR PADLOCK	V	V	PTFE COATED	STAINLESS STEEL
120B	VAPOR RECOVERY	V	V	PTFE COATED	STAINLESS STEEL
152-80	SATURATOR	V	V	PTFE COATED	STAINLESS STEEL
181 EN-P	IN-LINE DEFLAGRATION FLAME ARRESTER	V	V	PTFE COATED	STAINLESS STEEL
165	AIR SATURATION VESSEL	V	NR	PTFE COATED	STAINLESS STEEL
197 EN-P	PRESSURE VACUUM/VENT	V	V	PTFE COATED	STAINLESS STEEL
330 EN-P	FLAME ARRESTOR	V	V	PTFE COATED	STAINLESS STEEL
442-80AL	OVERFILL PREVENTION VALVE	V	V	PTFE COATED	STAINLESS STEEL
950	DIP STICKS	V	V	PTFE COATED	STAINLESS STEEL
1010EN-P	BALL FLOAT VENT VALVE	V	NR	PTFE COATED	STAINLESS STEEL

NR - NOT REQUIRED ONLY FOR DIESEL MANHOLE

Protection System intended for use in potentially explosive atmospheres Directive ATEX 2014/34/EU

TYPE	NORMS	PRODUCTS	MARKING
OVERFILL VALVES	UNI EN 13616-1:2016 UNI EN 13616-2:2016	442B-80AL / 442-80AL	Ex II 162B
IN-LINE DEFLAGRATION FLAME ARRESTORS	HARMONIZED STANDARD EN ISO 16852:2016	181 EN-P / 1010 ENP	Ex G IIB3
END OF-LINE DEFLAGRATION FLAME ARRESTORS	HARMONIZED STANDARD EN ISO 16852:2016	197 EN-P	Ex G IIB3 / Ex G IIC (HYDROGEN)